

MODELLO MOD.	CHIOCCIOLA DOPPIA PRECARICATA PRELOADED DOUBLE NUT	TAB.1 TAB.1	DIN69051/5 DIN69051/5
------------------------	--	-----------------------	---------------------------------

Ricircolo interno
Dispositivo di ricircolo in acciaio
Precarico = max. 10% di C dyn
Dimensioni speciali a richiesta
Raschiatori in materiale plastico (standard).
A richiesta in PTFE autolubrificante

Internal recirculation system
Steel-made recirculation device
Preload = max. 10% of C dyn
Special dimensions on request
Standard: Nylon wipers.
On request: Special selflubricating PTFE material

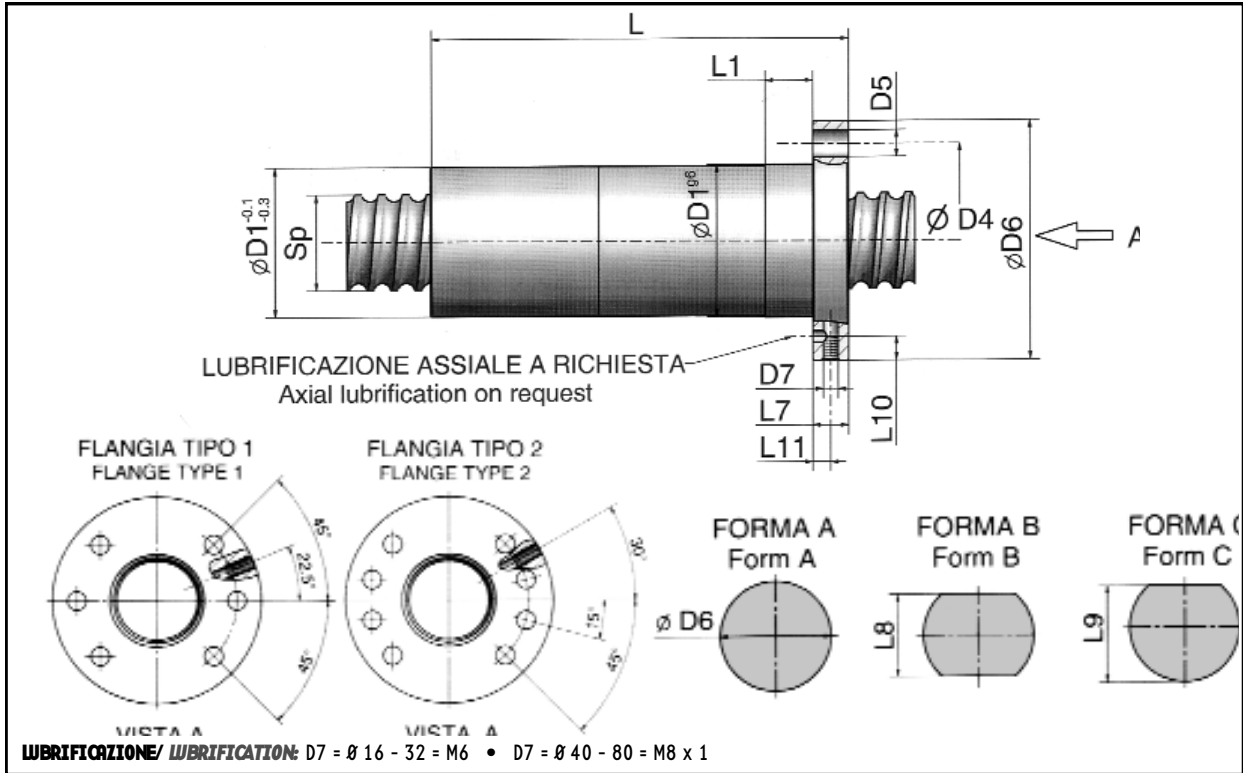

Tipo/ Size		Circuiti/ Effect. turns i	Capacità di carico/ Basic Rate Load		Rigidità/ Stiffness Rb/t KN/um	Dimens.chiocciola / Nut dimensions											Sfera Ball mm	Sp(h ₀) mm
d0 mm	Ph mm		C _{dyn} (KN)	C _{stat} (KN)		L mm	D1g6 mm	D4 mm	D5 mm	D6 mm	D7 mm	L1 mm	L7 mm	L8 mm	L9 mm	L10 mm		
16	4	3	8,05	11,08	1,05	70	28	38	5,5	48	10	10	40	44	5	2,38	16	
	5	3	8,05	11,08	1,04	75												
20	4	4	11,61	19,14	1,41	80	36	47	6,6	58	10	10	44	51	5	2,38	20	
	5	4	17,09	25,37	1,80	85												
25	4	3	9,61	16,95	1,08	75	40	51	6,6	62	10	10	48	55	5	2,38	24	
		4	12,53	23,19	1,43	82												
	5	3	16,24	24,39	1,38	78												
		4	21,18	33,48	1,82	88												
	6	3	16,23	24,37	1,38	84												
		4	21,17	33,45	1,82	96												
		2	10,98	15,20	0,92	87												
		3	16,17	24,24	1,37	107												
32	4	3	10,51	21,21	1,11	82	50	65	9	80	M6 Tipo - Type 1	10	12	62	71	8	2,38	30
		4	13,71	29,07	1,47	90												
		6	19,78	44,78	2,18	106												
	5	3	17,93	30,95	1,41	90												
		4	23,39	42,24	1,86	100												
		6	33,75	65,25	2,76	110												
	6	3	25,34	39,61	1,90	98												
		4	33,05	54,63	2,51	112												
		6	47,68	84,00	3,71	136												
		2	17,17	24,50	1,26	100												
	10	3	25,28	39,48	1,89	120												
		4	32,98	54,45	2,50	150												
		2	17,01	24,80	1,24	140												
	20	3	25,04	39,54	1,85	180												

Tipo/ Size		Circuiti/ Effect. turns i	Capacità di carico/ Basic Rate Load		Rigidità/ Stiffness Rb/t KN/um	Dimens.chiocciola / Nut dimensions											Sfera Ball mm	Sp(h6) mm
d0 mm	Ph mm		Cdyn (KN)	Cstat (KN)		L mm	D1g6 mm	D4 mm	D5 mm	D6 mm	D7 mm	L1 mm	L7 mm	L8 mm	L9 mm	L10 mm		
40	5	3	19,79	39,27	1,44	92	63	78	9	93	10	14	70	81,5	7	3,5	38	
		4	25,81	53,63	1,91	102												
		6	37,24	83,20	2,83	122												
	6	3	28,13	50,47	1,93	98												
		4	36,69	69,14	2,55	110												
		6	52,93	107,17	3,78	134												
	8	3	44,83	70,27	2,60	127												
		4	58,47	97,29	3,44	143												
		6	84,29	149,82	5,09	199												
	10	3	44,79	70,18	2,56	140												
		4	58,43	97,18	3,44	160												
		6	84,29	149,82	5,09	199												
16	2	30,33	44,32	1,73	136													
	3	44,65	71,18	2,58	168													
	4	58,24	96,69	3,42	200													
20	2	30,24	44,11	1,72	152													
	3	44,52	70,85	2,57	192													
	4	21,72	49,77	1,49	100													
50	5	3	21,72	49,77	1,49	100	75	93	11	110	10	16	85	97,5	8	3,5	48	
		4	28,33	68,49	1,97	110												
		6	40,87	105,51	2,93	130												
	6	3	30,99	64,21	1,98	112												
		4	40,42	87,94	2,62	124												
		6	58,31	136,10	3,85	148												
	8	3	61,68	102,11	2,64	130												
		4	80,45	141,82	3,49	146												
		6	116,06	217,47	5,17	178												
	10	3	61,65	102,03	2,63	145												
		4	80,41	141,71	3,49	165												
		6	116,01	219,19	5,16	205												
12	3	61,61	103,82	2,63	156													
	4	80,36	141,58	3,48	180													
	6	115,93	218,98	5,16	228													
16	3	61,52	103,58	2,67	160													
	4	80,24	141,24	3,47	200													
	6	115,93	218,98	5,16	228													
20	3	61,40	103,26	2,62	200													
	4	80,08	140,81	3,46	240													
	6	115,93	218,98	5,16	228													
63	5	3	21,72	49,77	1,54	100	90	108	11	125	10	18	95	110	9	3,5	60	
		4	28,33	68,49	2,04	110												
		6	40,87	105,51	3,03	130												
	6	3	33,85	80,83	2,03	105												
		4	44,16	110,35	2,69	117												
		6	63,70	170,10	3,98	141												
	10	3	68,35	130,14	2,69	140												
		4	89,15	177,99	3,56	160												
		6	128,61	275,60	5,27	200												
	20	3	94,87	167,01	3,79	230												
		4	123,74	230,77	5,02	270												
		6	128,61	275,60	5,27	200												
80	5	3	26,40	83,87	1,62	110	105	125	13,5	145	10	20	110	127,5	9	3,5	80	
		4	34,43	114,84	2,14	120												
		6	49,67	176,78	3,18	140												
	10	4	80,30	208,17	3,68	180												
		6	115,84	321,33	5,45	225												
		8	149,66	433,10	7,20	280												
	20	3	107,99	225,43	3,87	270												
		4	140,86	308,81	5,13	300												
		6	203,21	475,57	7,59	350												
	100	10	3	159,37	297,83	3,87												270
			4	207,87	406,14	5,13												300
			6	299,88	628,16	7,59												350
120	10	6	126,30	401,90	3,80	230	125	145	13,5	165	16	22	130	133	11	6,35	100	
		6	159	468	7,42	230												
		4	154,60	386,68	5,25	300												
	20	6	223,04	598,73	7,77	380												
		4	230,05	510,11	5,25	300												
		6	331,88	789,85	7,77	380												
	160	10	6	170,7	563	5,79												235
			4	248,63	619,48	5,37												310
			6	150,75	645,17	6,07												250
	160	20	6	402,91	1279,64	8,28												400
			4	248,63	619,48	5,37												310
			6	150,75	645,17	6,07												250

- A richiesta:
Sfere in materiale ceramico
Chiocciola in versione rotante
- Classi di precisione 1-3-5-7 secondo norme ISO/TC39/WG7 179
- Elica destrorsa standard
- Carichi secondo DIN 6905/4
- Rigidità chiocciola secondo DIN 69051/6

- On request:
Ceramic balls
Rotating nut
- Accuracy classes 1-3-5-7 according to ISO/TC 39/WG7 179
- R.H. thread as standard
- Load according to DIN 6905/4
- Nut stiffness according to DIN 69051/6